

REV	DESCRIPTION	DATE

## NOTES

**MATERIAL** TOP & BOTTOM 0.062" STEEL, SIDES, FRONT, REAR & HORIZONTAL SUPPORTS 0.125" ALUMINUM, DIMENSIONS ARE TAKEN WITH THE PAINTED SURFACE

**FINISH** TOP, BOTTOM & SIDE PANELS, TEXTURED BLACK, FRONT/REAR PANELS ON SMOOTH BLACK, ONE CONTEMPRA GRAY (RAL 7032), ALL POWDER PAINT,

# FRONT VIEW

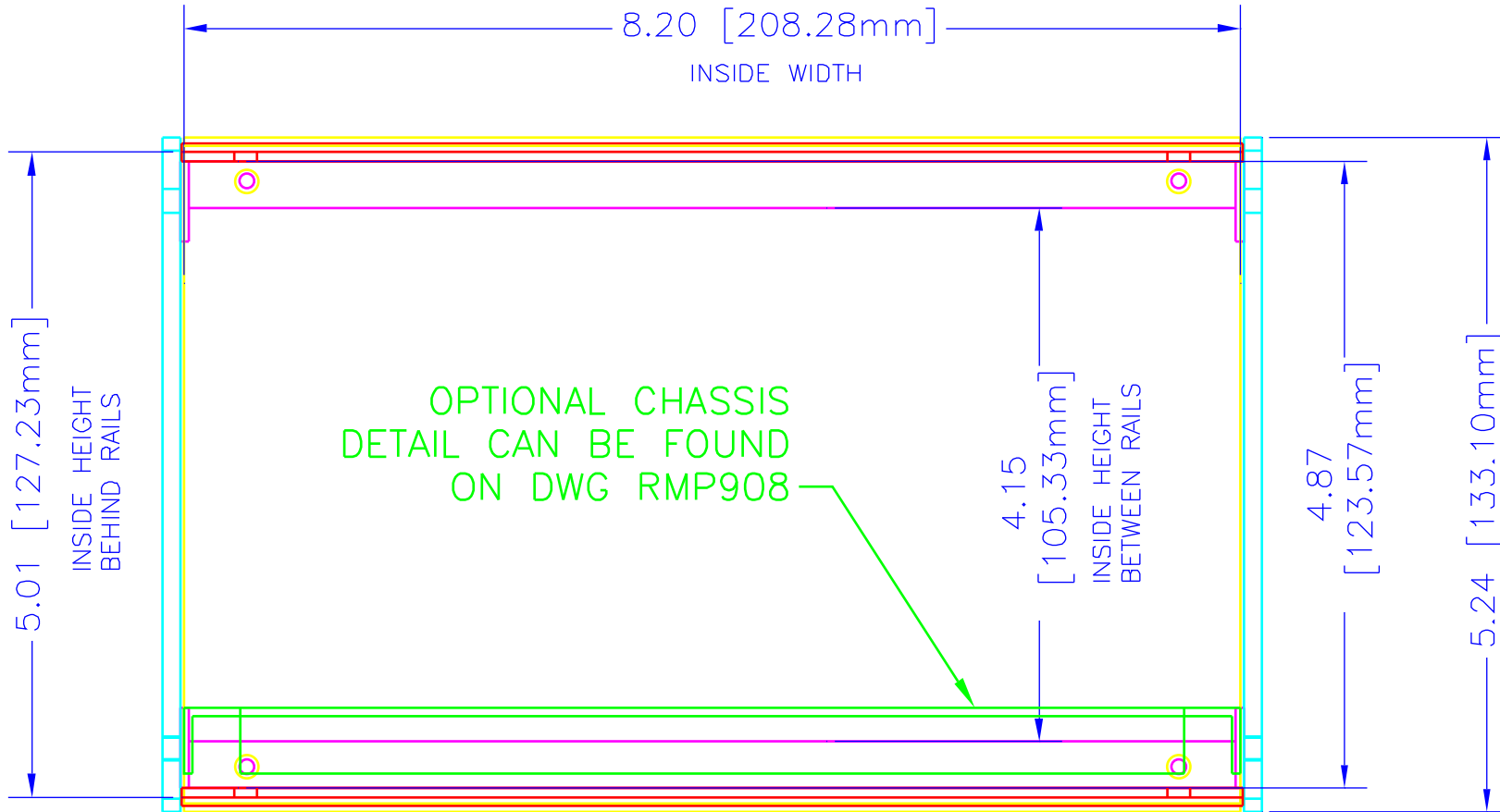

UNLESS OTHERWISE SPECIFIED  
DIMENSIONS ARE IN INCHES

X +/- .1  
XX +/- .02  
XXX +/- .015  
CH/IS +/- .005  
ANGLES +/- .5 DEG



**HAMMOND  
MANUFACTURING**

WEB: [WWW.HAMMONDMFG.COM](http://WWW.HAMMONDMFG.COM)

TITLE HAMMOND RMCS SERIES  
RACK ENCLOSURE

DRAWN BY MJM DATE 09/17/01

SCALE PAGE 1 OF 3

PART NUMBER

RMCS9058

# SIDE VIEW

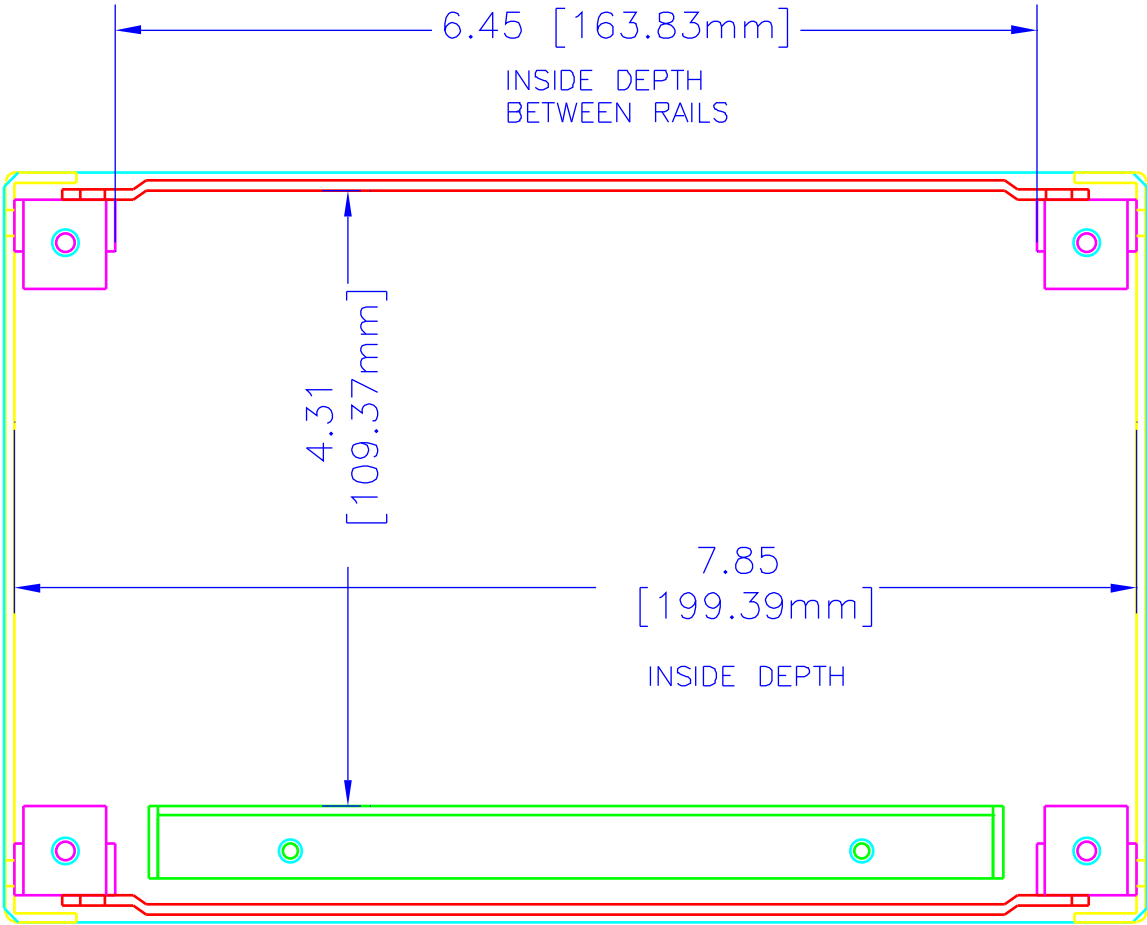

UNLESS OTHERWISE SPECIFIED  
DIMENSIONS ARE IN INCHES

X +/- .1  
XX +/- .02  
XXX +/- .015  
C/US +/- .005  
ANGLES +/- .5 DEG

NOTES:  
HAMMOND CLAIMS PROPRIETARY RIGHTS TO  
THE MATERIAL ON THIS DRAWING. IT IS  
INTENDED TO BE USED AS A REFERENCE FOR  
ENGINEERING INFORMATION ONLY. THIS  
INFORMATION MAY NOT BE USED TO  
MANUFACTURE PRODUCTS WITHOUT WRITTEN  
PERMISSION FROM HAMMOND MANUFACTURING.



**HAMMOND  
MANUFACTURING**

WEB: [WWW.HAMMONDMFG.COM](http://WWW.HAMMONDMFG.COM)

TITLE		HAMMOND RMCS SERIES RACK ENCLOSURE	
DRAWN BY	MJM	DATE	09/17/01
SCALE		PAGE	2 OF 3
PART NUMBER		RMCS9058	

# TOP VIEW

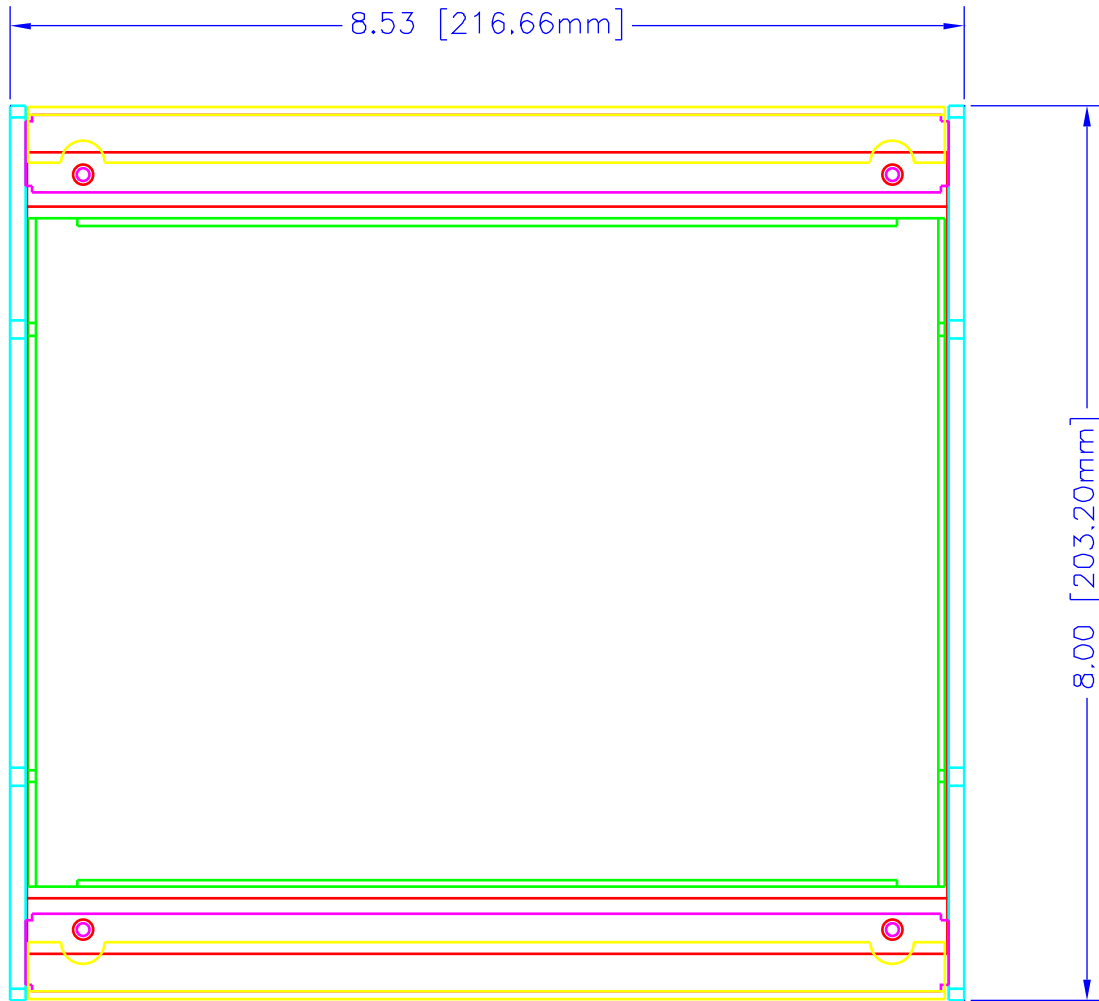

UNLESS OTHERWISE SPECIFIED  
DIMENSIONS ARE IN INCHES  
X +/- .1  
XX +/- .02  
XXX +/- .015  
ZUNS +/- .005  
ANGLES +/- 0 DEG.  
NOTES  
HAMDON CLAIMS PROPRIETARY RIGHTS IN  
THE MATERIAL ON THIS DRAWING. IT IS  
INTENDED TO BE USED AS A REFERENCE FOR  
ENGINEERING INFORMATION ONLY. THIS  
INFORMATION MAY NOT BE USED TO  
MANUFACTURE PRODUCT WITHOUT WRITTEN  
PERMISSION FROM HAMMOND MANUFACTURING.



**HAMMOND  
MANUFACTURING**

WEB: [WWW.HAMMONDMFG.COM](http://WWW.HAMMONDMFG.COM)

TITLE		HAMMOND RMCS SERIES RACK ENCLOSURE	
DRAWN BY	MJM	DATE	09/17/01
SCALE		PAGE	3 OF 3
PART NUMBER		RMCS9058	